

NEXUS

AUTOPILOT

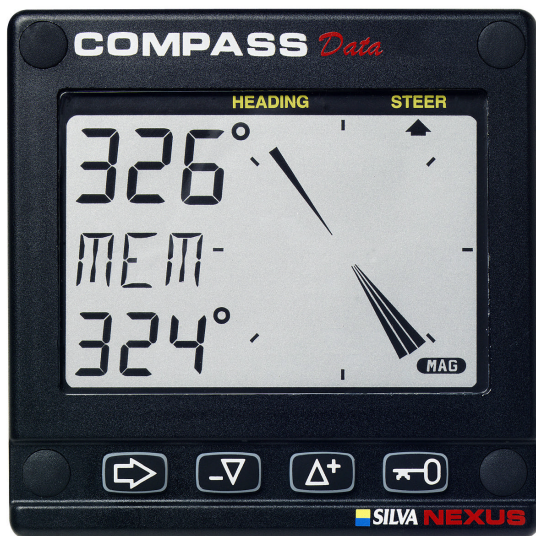

Installation and Operation Manual



This manual is written for:
Nexus Autopilot instrument (Art. No. 20445-5), for version 1.12>
Nexus Servo Unit A-1500 version (Art. No. 21035), for version 2.23>
Nexus Servo Unit A-1510 version (Art. No. 21035-2), for version 2.23>
Nexus Rudder Angle Transmitter (Art. No. 21036)

Edition: June 2000

1	Introduction.....	5
1.1	Welcome aboard!.....	5
1.2	Capabilities.....	5
1.3	Principle of operation.....	5
1.4	Components.....	6
1.4.1	Autopilot instrument.....	6
1.4.2	Servo Unit (A-1500 and A-1510).....	6
1.4.3	Rudder Angle Transmitter.....	6
1.4.4	Compass transducer.....	6
1.4.5	Pumpset.....	6
1.4.6	Linear Drive.....	7
1.4.7	Solenoid Valve Drive (A-1500 only).....	7
1.5	Registering this product.....	7
1.6	About this manual.....	7
2	First start.....	8
2.1	Initialising the instrument in a Nexus Network.....	8
2.2	Re-initialising the instrument.....	8
3	Operation.....	9
3.1	Instrument overview.....	9
3.1.1	Instrument display.....	9
3.1.2	Instrument pages and functions.....	9
3.1.3	Instrument modes.....	9
3.1.4	Instrument power on/off.....	9
3.2	How to use the push-buttons.....	10
3.2.1	MODE.....	10
3.2.2	LEFT.....	10
3.2.3	RIGHT.....	10
3.2.4	KEY.....	10
3.2.5	Clear.....	10
3.2.6	Setup mode.....	10
3.2.7	Lighting.....	10
4	Function.....	12
4.1	Standby mode.....	12
4.2	Autopilot mode.....	12
4.2.1	Activate automatic steering.....	12
4.2.2	Turn off automatic steering.....	12
4.2.3	Automatic steering by compass.....	12
4.2.4	Automatic steering by navigator.....	13
4.2.5	Automatic steering by wind.....	13
4.2.6	Power steering.....	15
4.2.7	Dodging and returning to last automatic steering function.....	15
5	Setup.....	16
5.1	Setup mode.....	16
5.1.1	The setup mode is divided into 4 setup groups.....	16
5.1.2	How to access setup mode.....	16
5.1.3	How to change a setting.....	16
5.1.4	How to return to previous mode.....	16
5.1.5	Factory default settings.....	16

CONTENTS

5.2	Lighting setup group [Lit].....	17
5.3	Autopilot setup group [P].....	17
5.3.1	P0, Return [RET].....	17
5.3.2	P1, Rudder [RUD].....	17
5.3.3	P2, Damping of compass heading [SEA].....	17
5.3.4	P3, Counter Rudder [CRD].....	18
5.3.5	P4, Damping of wind [WSE].....	18
5.3.6	P5, Automatic Trim Calibration [ATC].....	18
5.3.7	P6, Adaptive Control [ADC].....	19
5.3.8	P7, Automatic Pilot Calibration [APC].....	19
5.3.9	P8, Rudder Reduction Speed [RRS].....	19
5.3.10	P9, Rudder angle limit [LIM].....	19
5.4	Alarm setup group [A].....	20
5.4.1	A0, Return [RET].....	20
5.4.2	A1, Pilot Course Alarm [PCA].....	20
5.4.3	A2, Timer watch alarm [TMR].....	20
5.4.4	A3, Cross Track Error alarm [XTA].....	20
5.4.5	A4, Push-button beep [KEY].....	20
5.5	Compass setup group [C].....	20
5.5.1	C0, Return [RET].....	21
5.5.2	C1, Magnetic heading [MAG].....	21
5.5.3	C2, Local magnetic variation [VAR].....	21
5.5.4	C3, Auto-deviation [Auto DEV].....	21
5.5.5	C4, Check auto-deviation [Auto CHK].....	22
5.5.6	C5, Clear auto-deviation [Auto CLR].....	22
5.5.7	C6, Adjust compass alignment [ADJ].....	22
6	Maintenance.....	23
6.1	Instrument maintenance.....	23
6.2	Drive unit maintenance and inspection schedule.....	23
7	Fault finding.....	24
7.1	General.....	24
7.2	Symptom - Cause - Action.....	24
7.3	Nexus Network error messages with cause and remedy.....	27
8	Specifications.....	29
8.1	Technical Specifications.....	29
8.1.1	Autopilot instrument.....	29
8.1.2	Servo Unit A-1500.....	29
8.1.3	Servo Unit A-1510.....	29
8.1.4	Rudder Angle Transmitter.....	29
8.2	Nexus Network specification.....	30
8.3	Accessories.....	30
8.3.1	Autopilot instrument.....	30
8.3.2	Nexus Remote Control instrument.....	30
8.3.3	Nexus analog Rudder Angle instrument.....	30
8.3.4	Nexus Multi Control instrument with Server.....	30
8.3.5	External alarm buzzer.....	31
8.3.6	NFU jog lever.....	31
8.3.7	Other Nexus Accessories.....	31
8.4	Abbreviations.....	33
8.5	Warranty.....	36

9	Installation	38
9.1	Installation general.....	38
9.2	Installation alternatives	39
9.3	Autopilot instrument	39
9.3.1	Location of instrument.....	39
9.3.2	Installing instrument.....	39
9.4	Wire thickness	40
9.5	Servo Unit.....	41
9.5.1	Location of Servo Unit.....	41
9.5.2	Installing Servo Unit.....	41
9.5.3	Connecting Servo Unit.....	41
9.5.4	Safety switch.....	42
9.5.5	Dip switches.....	42
9.5.6	Trim potentiometers	43
9.5.7	NMEA connections.....	43
9.6	Rudder angle transmitter.....	43
9.7	Pumpset	43
9.8	Linear drive.....	44
9.9	Solenoid valve controlled pumpset	45
9.10	Other Accessories.....	45
10	Dockside Testing	46
10.1	Preparations.....	46
10.2	Dockside First Start	46
10.3	How to remove air from system	46
11	Sea Trials	47
11.1	Preparations.....	47
11.2	Compass calibration.....	47
11.3	Automatic Pilot Calibration [APC]	47
12	Fine tuning.....	48

Operator Warning!

An Autopilot is an aid to navigation only. It is not intended or designed to replace the man on watch. Always be in position to monitor the boat's heading and to watch for navigational hazards. Be prepared to revert to manual steering immediately, if an undesired change of heading occurs, if the heading is not maintained within reasonable limits, or when navigating in a hazardous situation.

Always remember: Whenever underway, a qualified man on watch is required.

It is the skippers responsibility to provide for a power safety switch, mounted within reach for the helmsman, and to brief all crew members that the Nexus Autopilot must be turned off with the red push-button **KEY**, to enable manual steering.

1 Introduction

1.1 Welcome aboard!

Thank you for choosing a Nexus Autopilot. Through this manual we would like to help you install and operate your Nexus product. We are convinced that you will appreciate the useful functions. To get the most out of your Nexus product, please read through this manual carefully before you start your installation. If you see us at a show, please stop by and say hello.

Good luck and happy boating!

1.2 Capabilities

Accuracy, reliability and simplicity of use, are key features of the Nexus microprocessor controlled Autopilot. Whether the need is for minimised fuel consumption, improved navigational accuracy or simply more enjoyable yachting, the Nexus Autopilot is the right navigational aid to provide precision steering under all sea conditions. Due to the very stable fluid dampened compass with high gimbaling angles and automatic trim feature, this Autopilot is suitable for sailing and powerboats. User adjustable settings make it possible to fine tune each boat, yet factory default settings and automatic calibration allow simple operation with minimal operator input.

The Nexus Autopilot is capable of operating either as a "Stand Alone" Autopilot, or as a "Network" application by connecting it to the Nexus Network. Many options are available, including GPS and wind transducers, Nexus Remote Control instrument and other Nexus digital and analog instruments.

The Autopilot Servo Unit A-1500 is designed for sailing and power boats from 35 ft. (11 m.) to over 160 ft. (50 m.), depending on drive units used. Hydraulic drive units provide precise control with low power consumption. Connection can also be made to solenoid valves of electro-hydraulic steering systems, allowing use on very large boats. Hydraulic linear drives provide powerful and accurate control when connected to mechanical steering systems and also provide independent hydraulic steering for added safety.

The Autopilot Servo Unit A-1510 is designed for sailing and power boats from 26 ft. (8 m.) to over 50 ft. (15 m.), depending on drive units used. Hydraulic drive units provide precise control with low power consumption. Hydraulic linear drives provide powerful and accurate control when connected to mechanical steering systems and also provide independent hydraulic steering for added safety.

Power steering through the instrument's push-buttons may be used to avoid heavy wheel effort when manoeuvring. Alarms for off course, off track or watch alarm are included with provision for an optional external alarm buzzer.

1.3 Principle of operation

Any difference between the set and actual course, is compared along with rate of change and trends in change*, to drive the pumpset motor or solenoid valve. The , rudder is moved as necessary to return the boat back on course. The sensitivity to course errors and amount of correction are user adjustable to suit different boats under various sea conditions.

NB * (PID control, terminology as known by control technicians,

P = proportional part, I = integral part and D = derived part)

Factory default settings and automatic calibration, establish a basis for normal steering and may be further fine tuned if necessary. During set up routines, the compass is automatically compensated and installation errors such as reversed rudder feedback and reversed pumpset wiring or piping are automatically diagnosed and corrected. During this routine also the rudder speed is automatically optimised. This greatly reduces installation set up and sea trials time while eliminating possible Autopilot malfunction.

1.4 Components

1.4.1 Autopilot instrument

Control and display of all Autopilot functions are provided by the Autopilot instrument. It is waterproof and may be mounted below or above deck. Multiple Autopilot instruments can be connected and the Autopilot may be activated by pressing the push-buttons of any instrument.

1.4.2 Servo Unit (A-1500 and A-1510)

The Servo Unit contains the course computer and pumpset motor drive circuitry and acts as a centre for interconnecting wiring. It is splash proof and should be located centrally to minimise lengths of wiring. The powerful microprocessor in the Servo Unit accepts heading information direct from an electronic compass or gyro compass (A-1500 only), wind transducer, navigators and compares this against the course set by the instrument and rudder.

1.4.3 Rudder Angle Transmitter

The Rudder Angle Transmitter provides the Autopilot with accurate rudder position information. It is mounted near the rudder shaft and connected to the tiller arm or quadrant with an adjustable ball joint linkage.

1.4.4 Compass transducer

No Autopilot can steer better than the compass stability will allow. The Nexus compass excels in this characteristic, where the liquid dampening provides for stability even at high speeds in heavy seas. The high gimbaling angle, eliminates compass disturbance with boat heeling or rolling. The compass provides a stable heading reference for the Autopilot and should be bulkhead mounted below deck near the centre of pitch and roll for maximum stability. Construction is splash proof. The Autopilot Servo Unit or the Nexus Server can re-transmit the compass heading on the NMEA output port to receivers such as radars, plotters, compass repeaters etc.

1.4.5 Pumpset

Various sizes and types of pumpsets can be mounted into a hydraulic steering system. The pumpset only operates when carrying out a rudder command. When the boat is on course, the pumpset motor stops. A variable speed motor drive adjusts optimal rudder speed and provides for minimum power consumption and maximising of rudder positioning accuracy.

1.4.6 Linear Drive

A hydraulic linear drive is used to drive the tiller arm or quadrant of mechanical steering systems. The linear drive is driven by a pumpset. The linear drive provides a cleaner installation, being entirely below deck, and delivers more torque to the rudder than wheel driven units. In case the mechanical steering should fail, the linear drive will provide a back-up hydraulic steering.

1.4.7 Solenoid Valve Drive

On larger boats the main hydraulic steering may be fitted with solenoid valve controlled power steering. In this case the Autopilot does not need to be supplied with a pumpset since the Nexus Servo Unit output can be reconfigured with its board mounted DIP switch to provide drive for steering solenoids or relays having coil voltages of 12 or 24 VDC.

1.5 Registering this product

Please take time to fill in the warranty cards and return them to your national distributor.

By returning the warranty card, it will assist your expert distributor to give you prompt attention. Keep your proof of purchase. Also, your details are added to our customer database so that you automatically receive new product catalogues when they are released.

1.6 About this manual

- Each time a push-button is referred to in this manual, the push-button name will appear in **bold** and CAPITAL letters, e.g. **MODE**.
- Unless otherwise stated, the push-button presses are momentary.
- Each time a function is mentioned in the text, it will be in brackets and in the same format, where possible, as displayed, e.g. [HDG] for HeadInG.
- With the word navigator we mean a GPS, Loran or Decca instrument.
- Which instrument is navigating? By the term navigating, we mean the active instrument in which the waypoint memory is used for navigation to calculate the navigation data, i.e. BTW, DTW etc. There can only be one instrument on the Nexus Network which is keeping the waypoints in memory, but the waypoints can be reached from all instruments.

Note! We have put in a lot of effort, in order to make this manual correct and complete. However, since we have a policy of continuous improvement, some information may differ from the product functions. If you need further information, do not hesitate to contact your national distributor.

2 First start

At each power on, the instrument will perform a self test. The display will first show all segments, then the software version and the Nexus Network ID number.



2.1 Initialising the instrument in a Nexus Network

At the first power on after installation, you will be asked to press **KEY** [PrSKEY]. This will give the instrument a logical ID number from 16 and upwards on the Nexus Network.



To initialise the instrument, press **KEY, one instrument at a time**, on all installed digital instruments,.

Warning! Always wait for the text [Init OK] to be displayed, before you press KEY on the next instrument!



The Nexus Servo Unit or the Server automatically gives the first unit ID number 16, then 17 and so on. The order in which you press **KEY**, will be the same order as the instruments will be given a logical ID number on the Nexus Network, and the same order they will be addressed by the Remote Control instrument if used.

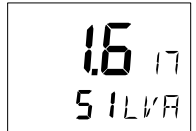

The example shows that the instrument version number is 1.6 and the logical ID number given is 17.

Warning! Do not activate any Autopilot functions until Dockside Testing and Sea Trials APC routine have been performed.

2.2 Re-initialising the instrument

If two instruments have been given the same ID number by mistake, you must re-initialise the instruments to avoid Network disturbance and blockage of data.



To re-initialise the instrument, be prepared to press **DOWN** and **UP** together during the short power up sequence, i.e. when version and ID numbers are displayed.

The display test is then re-started on all instruments and you will be asked to press **KEY** on one instrument at the time as explained above.

Note! If you do not succeed to re-initialise, we suggest you disconnect (just pull out the connection plug) on all, except one of the instruments that had the same ID number, then re-install the instruments and repeat the above procedure.

3 Operation

3.1 Instrument overview



3.1.1 Instrument display

The display consists of two lines, a top-line with 24 mm (1") digits and a lower-line with 13 mm (0.5") digits.

3.1.2 Instrument pages and functions

The Autopilot instrument has its functions divided into 4 pages. The page names are printed above the display:

COMPASS, NAV (Navigation), WIND and PWR ST (Power steer)

The selected function is indicated by the page-arrow at top of the display.

3.1.3 Instrument modes

Standby mode: The instrument functions as a passive compass repeater.

Autopilot mode: When any Autopilot function is activated.

Setup mode: It allows calibrating your Network settings.

Edit mode: It allows editing settings (when digits are flashing).

3.1.4 Instrument power on/off

You will switch on/off your Nexus instruments by using the instrument switch on your electrical panel as the instruments have no separate power on/off-button.

3.2 How to use the push-buttons

3.2.1 MODE

A press on **MODE**, moves one page to the right, indicated by the page-arrow at top of the display.



In edit mode, a press on **MODE** moves the cursor one step to the right.

It scrolls in a circular pattern, one step for every press.

3.2.2 LEFT

When the Autopilot is activated, a short press on **LEFT** decreases the course by 1°, a long press decreases the course by 10°.



In setup mode a press on **LEFT** moves to the previous setup function.

In edit mode a press on **LEFT** decreases a digit by one.

3.2.3 RIGHT

When the Autopilot is activated, a short press on **RIGHT** increases the course by 1°, a long press increases the course by 10°..



In setup mode a press on **RIGHT** moves to the next setup function.

In edit mode a press on **RIGHT** increases a digit by one.

3.2.4 KEY

A press on **KEY** activates the Autopilot in selected steering function.

A second press on **KEY** turns off the Autopilot.

The text OFF is printed above **KEY**, which also is coloured red.



In setup mode, a press on **KEY** unlocks a digit to access edit mode. When unlocked, the digits are "active" (flashes) and can be edited by pressing **LEFT**, **RIGHT** and **MODE** as required.

When finished editing, lock the digit by another press on **KEY**.

3.2.5 Clear

A press on **LEFT** and **RIGHT** together, clear digits in edit mode.



3.2.6 Setup mode

To access setup mode, press and hold **MODE** more than 2 seconds. [Lit OFF] flashes. To move to next setup group, press **MODE** again.

To return to standby mode, press **KEY** when the text return [RET] is displayed.



> 2sec

3.2.7 Lighting

The instrument uses red back lighting for the display and the 4 push-buttons. The light can be set at 4 different levels.

OPERATION

To access the light control, press and hold **MODE** for more than 2 seconds. The flashing text [Lit OFF] will be displayed and the display will be lit momentarily.

To select between the 4 light levels [LOW], [MID], [MAX] and [OFF], press **RIGHT**. To lock the selected level, press **KEY**.

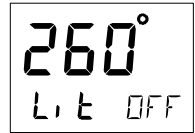

The selected light level will be copied to all Nexus instruments connected to the Network. It is not possible to reduce or turn off the lighting on an individual instrument.

4 Function

4.1 Standby mode

At power on the Autopilot starts in standby mode and operates as a passive compass repeater. No page-arrow is shown at the top of the display.

The current course is displayed on the top-line.

The rudder angle is displayed on the bottom line.

In any function, the top-line displays the heading at all times.

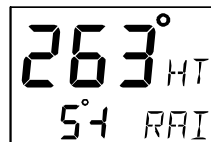

4.2 Autopilot mode

Prior to activating any automatic steering function, the boat should be steadied on the desired heading and on track for 5 to 10 seconds to minimise large course changes when activated. The Autopilot operates with course errors up to 90°, and cross-track-errors of max 2 NM.

4.2.1 Activate automatic steering

To select a steering function, press **MODE**.

The page-arrow at top of the display indicates the selected page.

To activate the selected steering function, press **KEY** when the lower-line text is flashing.

The reversed lit text [AUTO] to the right and in the middle on the display always confirms that an automatic steering function is activated. The function text at lower-line to the right confirms which steering function is activated, ex [HDG] for compass steering.



Note! If a page is not available, such as when no waypoint information is programmed / activated or no navigator or wind transducer connected, the page-arrow will not stop at that page.

4.2.2 Turn off automatic steering

To turn off automatic steering, press **KEY**.

The text OFF is also printed above **KEY**.

To turn off the Autopilot when you are in the process of changing functions or are in setup mode, press and hold **KEY** for more than two seconds.

4.2.3 Automatic steering by compass

To select compass steering, press **MODE** until the page-arrow appears under COMPASS, and [HDG] is flashing on the lower-line. Your present course is displayed on the top-line. This course will become the reference course the Autopilot will keep when automatic steering by compass is activated.

To activate compass steering, press **KEY** when [HDG] is flashing.

The present heading now becomes the reference course and is displayed on the lower-line to the left.

To change the reference course to port, press **LEFT**.

To change the reference course to starboard, press **RIGHT**.



A short press changes the course by 1°, a long press by 10°.

4.2.4 Automatic steering by navigator

Automatic steering by navigator is only possible if a navigator is connected and it is navigating towards a waypoint.

To select steering by navigator, press **MODE** until the page-arrow appears under NAV, and [NAV] is flashing on the lower-line. Your present course is displayed on the top-line.

Caution! Before activating [NAV] steering, make sure your present heading corresponds approximately with bearing to waypoint, and that the cross track error is less than two NM, because the Autopilot will turn the boat towards the track line first and then onto the heading set.

To activate NAV steering, press **KEY** when [NAV] is flashing. Bearing to waypoint or cross track error to waypoint are now displayed on the lower-line to the left. To alternate the display between bearing and track on the lower-line, press **LEFT** or **RIGHT**.



XTE to starboard



XTE to port

Caution!

The NAV function will automatically change course when the next waypoint information is displayed and the helmsman should ensure that there are no boats or other hazards on the new course as the waypoint is changing. When using waypoint sequencing in a route list, it is extremely important that the helmsman is at the steering position and ready to override the pilot if the course change would cause collision with other boats or objects.

Set all waypoints in navigators away from navigational hazards by at least 100 metres as the boat may require this radius or more on waypoint advance. The Nexus GPS Navigator will allow you to select a route list with automatic sequencing, or with a confirming push-button press for each waypoint.

4.2.5 Automatic steering by wind

Automatic steering by wind is only possible if the Autopilot is connected to a Nexus Network with a wind transducer connected.

Note! The apparent wind speed must be more than 3 knots. If the apparent wind speed falls below 3 knots, wind signals are disabled and the Autopilot will maintain the current magnetic heading reference instead.

Before activating wind steering, optimise your sail trim.



FUNCTION

To select wind steering, press **MODE** until the page-arrow appears under WIND, and Apparent Wind Angle [AWA] is flashing on the lower-line. Your present course is displayed on the top-line.

To activate wind steering, press **KEY** when [AWA] is flashing.

The present [AWA] now becomes the reference angle, and is displayed on the lower-line to the left, followed by a sign to describe wind from port or starboard.

To steer to port, press **LEFT**.

To steer to starboard, press **RIGHT**.

A short press changes the value by 1°, a long press by 10°.

When making large changes of over 30°, it may take about 1 minute for an accurate course to be re-established due to changes in boat balance which must be recognised by the automatic trim function.

To tack, press **RIGHT** and **LEFT** together and the boat will come about the same apparent wind angle on the opposite tack.

Tack angles greater than 80° off the wind are not recommended due to the possibility of an accidental gibe.

Warning! Pressing for a tack when the wind is abaft the beam will result in a gibe!



4.2.6 Power steering

To select power steering, press **MODE** until the page-arrow appears under PWR ST, and Rudder Angle Indicator [RAI] is flashing on the lower-line. Your present course is displayed on the top-line.



To activate power steering, press **KEY** when [RAI] is flashing. The rudder angle, followed by a sign for port or starboard is displayed on the lower-line.

To change the rudder angle to starboard press **RIGHT** and hold it, until the desired rudder angle is displayed.

To change the rudder angle to port press **LEFT** and hold it, until the desired rudder angle is displayed.

4.2.7 Dodging and returning to last automatic steering function

To dodge, turn off the automatic steering by pressing **KEY** and dodge manually.

If you want to re-activate the last steering function and value, press **MODE** and **KEY** together, within 10 minutes after turning off the automatic steering.

This function is not available after 10 minutes after Autopilot off, or if the Autopilot has been turned off by pressing **KEY** for more than two seconds.

5 Setup

5.1 Setup mode

To get the most out of your Nexus product, it is important to carefully setup and calibrate your Network. The settings are stored in a non-volatile memory, which means they will remain in memory after you have turned off the power. To get an overview of your Network settings, we recommend that you note your settings.

5.1.1 The setup mode is divided into 4 setup groups

[Lit OFF]	= Lighting setup group
[P0] - [P9]	= Pilot setup group
[A0] - [A4]	= Alarm setup group
[C0] - [C6]	= Compass setup group

5.1.2 How to access setup mode

To access setup mode, press and hold **MODE** more than 2 seconds.

To move to next setup group, press **MODE**.

To scroll up and down in each group press **LEFT** or **RIGHT**.

5.1.3 How to change a setting

To unlock a setting, press **KEY**.

To change a setting, press **LEFT**, **RIGHT** and **MODE** as required.

To lock a setting, press **KEY**.

5.1.4 How to return to previous mode

To return to previous mode, press **KEY** when the text return [RET] is displayed.

5.1.5 Factory default settings

After each setting we have listed the factory default settings. This allows you to manually get back to factory default settings, if needed. There is no automatic way to get back to factory default settings, it has to be done manually.

All Autopilot instrument settings are central, and affect all connected Autopilot instruments and their commands.

Note! The APC routine automatically sets these settings:

[RUD], [SEA], [CRD], [ATC] and [RRS].

Therefore these settings and their minimum and maximum values and times, depend on how your boat behaves.

Note! The above explanation is only mentioned here. It is not repeated for each setup.

Caution! All setup routines can be adjusted while the boat is underway with Autopilot functions activated. Always be in a position to monitor the boat's heading and to watch for navigational hazards when calibrating the Autopilot. Be prepared to turn off the Autopilot by a long press on **KEY**, to revert to manual steering immediately if an undesired heading occurs. If navigating with an automatic steering function in a hazardous situation, do not adjust setup routines while underway.

5.2 Lighting setup group [Lit]

The instrument uses red back lighting for the display and the 4 push-buttons. The light can be set at 4 different levels of brightness.

To select between the 4 light levels [LOW], [MID], [MAX] and [OFF], press **RIGHT**. To lock the selected level, press **KEY**.



The selected light level will be copied to all Nexus instruments connected to the Network. It is not possible to select the lighting level individually for single instruments.

5.3 Autopilot setup group [P]

5.3.1 P0, Return [RET]

To return to previous mode, press **KEY** when the text [RET] is displayed.



5.3.2 P1, Rudder [RUD]

Possible settings are [0] = Minimum to [9] = Maximum. Set by the APC routine. The setting affects the degree of rudder angle used.

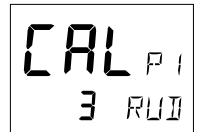

The most critical adjustment for good steering is the rudder. Too high a setting will cause excessive amounts of rudder movement, which forces the boat to hunt rapidly back and forth across the course. Too low a setting lets the boat slowly fall off course, with repeated corrections required to get back on course.

The rudder should be set to the position where positive control of the steered course desired, is achieved without undue activity. Run the boat at its cruising speed and make a course change of 40°, with the push buttons. The boat should not overshoot by more than approximately 5°. Adjust the rudder until this is achieved.

5.3.3 P2, Damping of compass heading [SEA]

Possible settings are [0] = Minimum to [9] = Maximum. Set by the APC routine.

This setting is a combination of yaw dead-band (compass sensitivity) and compass damping. The minimum setting may only be used under calm sea conditions to avoid unnecessary rudder correction due to compass acceleration errors.

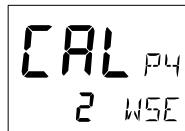

Smaller boats and high speed boats, which are subject to more acceleration in lighter seas will have to use higher settings. Larger and more stable boats can use lower settings since there is less compass disturbance.

Default setting should work on most boats in light to moderate sea conditions. Following seas, no matter how rough, may require lower settings to catch course error trends quickly in order to minimise excessive yaw.

5.3.4 P3, Counter Rudder [CRD]

Possible settings are [0] = Minimum to [9] = Maximum. Set by the APC routine.

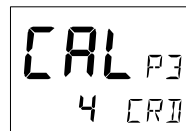

This setting senses the rate of change of heading and gives additional rudder corrections if the boat is rapidly falling off course, and backs off the rudder as a boat approaches the desired heading. Its effect is to rapidly catch the tendency to yaw in a quartering sea, provide initially high rudder control when making a large course change and to decelerate the swing of the bow, as a boat approaches the desired course.

Course holding with heavy and difficult to steer boats, is greatly improved, when using this feature. Too little counter rudder, will allow the boat to overshoot on large course changes. Too much will cause unnecessary rudder corrections and a tendency to stop short of coming to a new course, requiring several successive corrections before easing up to the new heading.

To optimise counter rudder, initially set it to minimum and adjust the rudder (see, [RUD] 5.3.2). Increment the counter rudder one step at a time, while testing 40° course changes, until the boat achieves an overshoot of 1° to 2° or less. Remember, that any air in the hydraulic system will prevent precision control.

5.3.5 P4, Damping of wind [WSE]

Possible settings are [0] = Minimum to [9] = Maximum. Default setting is [2].

Damping of wind transducer. The factory default setting should be adequate. In very heavy weather or unstable wind conditions, unnecessary corrections may be minimised by increasing the setting.

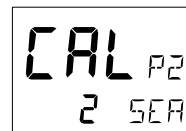

5.3.6 P5, Automatic Trim Calibration [ATC]

Possible settings are [0] = Minimum to [9] = Maximum.

Set by the APC routine.

[ATC] is not critical. It constantly compares the course set against the course steered and slowly applies more rudder as necessary to reduce any errors to zero. Errors may be due to wind, waves or other unbalanced forces such as single screw operation of a twin screw boat, an off centre tow or weather helm on a sailing boat, etc. If the trim time is set too high, it will take a long time to eliminate the course error. If it is set too low it can start to degrade course stability.



In general, longer trim times (higher settings) should be set for large boats and sailing boats and shorter trim times (lower settings) for small boats and high speed planning boats. The factory default setting should be acceptable for all but extreme applications.

5.3.7 P6, Adaptive Control [ADC]

Possible settings are [OFF] or [On].
This function is reserved for future functions.



5.3.8 P7, Automatic Pilot Calibration [APC]

Possible settings are [ON] or [OFF].
The APC routine automatically sets: [RUD], [SEA], [CRD], [ATC] and [RRS].



The Autopilot will not function unless the boat pass the APC routine. The APC will automatically determine and correct how wires and pipes are connected. It will also learn how the boat reacts on different rudder commands and automatically calibrate itself.

To learn how to perform the APC function, see Sea Trials.

5.3.9 P8, Rudder Reduction Speed [RRS]

Possible settings are [0] = Minimum to [9] = Maximum.
Set by the APC routine.

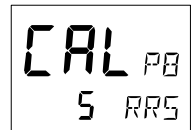

The [RRS] controls the flow of the pumpset. It will effect the pumpset, but not a solenoid valve steering system.

The [RRS] will be set to [5] after the APC routine is performed. It is then possible to increase or decrease the speed reduction of the pumpset motor.

5.3.10 P9, Rudder angle limit [LIM]

Possible settings are [0°-99°]. Default setting is [00°].

An angle of 00° is the same as rudder angle limit disconnected (OFF).

Note! Make sure [LIM] is set to 00° (OFF) during installation.

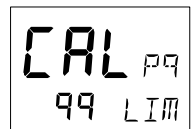

The rudder angle limit sets maximum angle for the rudder. If the limit is set to 45°, it is not possible to exceed a rudder angle 45° on either port or starboard. Check the maximum rudder angle by turning the steering wheel to port and starboard and read the maximum angle. If the angle is greater on one side, decrease the smallest angle by 3°, and enter that setting as the limit.

5.4 Alarm setup group [A]

To silence an alarm, press any push button.

5.4.1 A0, Return [RET]

To return to previous mode, press **KEY** when the text [RET] is displayed.



5.4.2 A1, Pilot Course Alarm [PCA]

Possible settings are [OFF] and [00°-99°]. Default setting is [OFF].

When the boat's average course differs more than the [PCA] setting, the alarm will sound and the display will blink.



5.4.3 A2, Timer watch alarm [TMR]

Possible settings are [OFF] or [On]. Default setting is [OFF].

On = audible alarm activated.

The audible alarm will sound every 5 minutes to alert the person on watch.

To confirm and restart the timer, press any push-button. If not confirmed within 1 minute, the optional external alarm buzzer, if connected to the Nexus Server, will sound for 1 minute, to alert the rest of the crew.



5.4.4 A3, Cross Track Error alarm [XTA]

Possible settings are [0.00] = OFF to [9.99]. Default setting is [0.00].

This function is only available in NAV function when the Autopilot is connected to a Nexus Network and a navigator is connected to the Nexus Server.

If the pilot's cross track error exceeds the set threshold of distance of the track, the alarm will be activated.



5.4.5 A4, Push-button beep [KEY]

Possible settings are [OFF] or [On]. Default setting is [ON].

[On] = Sound when push buttons are pressed. [OFF] = No sound.



5.5 Compass setup group [C]

Auto-deviation, auto-deviation-check and auto-deviation clear, are only available if a Nexus compass transducer is connected. The auto-deviation routine will automatically correct all possible faults, except alignment.

Note! As soon as you place any kind of ferrous items close to the compass, the auto-deviation and auto-deviation check routines should be

repeated. So if you have packed your boat for the vacation, think about where you place ferrous items in relation to the compass transducer.

5.5.1 C0, Return [RET]

To return to previous mode, press **KEY** when the text [RET] is displayed.



5.5.2 C1, Magnetic heading [MAG]

Possible settings are [OFF] and [On]. Default setting is [OFF].

[On] = All headings will be magnetic.

[OFF] = All headings will be true, i.e. corrected for local variation set in C2, Local variation [VAR]. This is local setting.



5.5.3 C2, Local magnetic variation [VAR]

Possible settings are [+/-00.0°-99.9°]. Default setting is [00.0°]

Easterly variation = underlining () sign.

Westerly variation = minus (-) sign.

The local magnetic variation is usually printed in the sea chart.



5.5.4 C3, Auto-deviation [Auto DEV]

This function is used to automatically correct the deviation of your compass.

Take the boat into a slow turn, in calm sea and away from other boats or obstructions. There is no need to perform a perfect circle.



When steady, select C3 [Auto DEV] and press **KEY** to start. The present "uncorrected" compass heading is displayed and the compass auto-deviation is in progress. Turn the boat in a 1 ¼ circle, and when ready press **KEY** again.

If successful, the text [CAL C3] [Auto DEV] will be displayed.

If not, an error messages can be displayed:

- [Err 15]: Make sure an Autopilot function is not activated and carry out the auto-deviation procedure again.
- [Err 16]: Auto-Deviation is not possible, because a NMEA compass is selected as compass for the Nexus Network.
- [Err 17]: The 1 ¼ turn was not performed or the compass is affected by strong magnetic distortion.

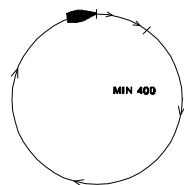

You may interrupt the auto-deviation procedure at any time by pressing **LEFT** and **RIGHT** together.

To check the auto-deviation, carry out the auto-deviation check routine.

5.5.5 C4, Check auto-deviation [Auto CHK]

This function is used to check your auto-deviation.

The result of [Auto CHK] will be compared with [Auto DEV]. If the deviation is less than 1,5°, the average value from the comparison between [Auto DEV] and [Auto CHK] will be stored.

Take the boat into a slow turn, in calm sea and away from other boats or obstructions. There is no need to perform a perfect circle.

When steady, select C4 [Auto CHK] and press **KEY** to start.

The present compass heading is displayed and the compass auto-deviationcheck is in progress. Turn the boat in a 1 ¼ circle, and to end the routine, press **KEY** again.

If successful, the text [CAL C4] [Auto CHK] will be displayed.

If not, [ERR 17] or [ERR 19] will appear, i.e. the difference between the last auto-deviation and this auto-deviationcheck was too great to be accepted.

Make a new auto-deviation-check, and if you still get [ERR 19], make a new auto-deviation, since the last one was probably disturbed.



5.5.6 C5, Clear auto-deviation [Auto CLR]

To clear the calibration created by the auto-deviation, select C5 [Auto CLR], and press **KEY**.



5.5.7 C6, Adjust compass alignment [ADJ]

Possible settings are [000°] to [359°]. Default setting is [000].

Compass transducer alignment correction or the so called, "A-fault".

Allows 180° reversed mounting if needed. Never mount the transducer at right angles to the boats fore-aft line.

Make sure that the local magnetic variation is entered before you make the alignment adjustment, otherwise you are unable to see the difference between local magnetic variation and alignment error.



To check the transducer position, sail/steer your boat in a straight line towards two visible objects in a line. If the actual heading taken from the sea chart is 330° and the compass displays 335°, then set the value of 360° - 5° to 355°.

6 Maintenance

6.1 Instrument maintenance

- To clean the instrument, use only mild soap solution and rinse with water.
- Do not use detergents or high pressure washing equipment.
- At least once a year, check all your connections and apply additional silicon paste at each connection point.
- When the instrument is not in use, always fit the instrument cover for protection
- Storing of instruments when not in use for longer periods: It is advisable to remove the instruments and transducers and store them inside the boat or at home preferably at room temperature.

6.2 Drive unit maintenance and inspection schedule

If the boat does not accumulate below hours within 3 months, the frequency is every 3:rd month.

Warning!

Failure to rectify any faulty conditions discovered as a result of the inspection could cause sudden loss of Autopilot control, with consequential danger. It is recommended that all items referenced in the following table be inspected before commencing any cruise.

Type	Equipment	Checks	Remedy	Inspection frequency
Hydraulic	Oil reservoir level	Correct	Fill	200 hrs
	Oil condition	Discoloration Contamination	Flush system and replace the oil	1000 hrs 1000 hrs
	Hydraulic piping	Damage Leaks & Corrosion	Replace	1000 hrs
	Hydraulic fittings	Damage Leaks & Loosening	Replace Tighten	500 hrs
	Piston rod seals on pumpset	Leaking	Replace	1000 hrs
Mechanical	Linear drive	Corrosion	Replace or Repair	2000 hrs
	Tiller arm	Corrosion	Replace	2000 hrs
	Tiller bolts	Corrosion Loosening	Replace Tighten	2000 hrs 500 hrs
	Rod end bolt on linear drive	Corrosion Loosening	Replace Tighten	2000 hrs 500 hrs
	Trunnion bolts on linear drive	Corrosion Loosening	Replace Tighten	2000 hrs 500 hrs

7 Fault finding

7.1 General

Before you contact your Nexus dealer and to assist your dealer to give you a better service, please check the following points and make a list of:

- All connected instrument and transducers, including their software versions.
- Nexus Network ID numbers for each instrument (displayed at power up).

In most cases, the reason for faults in electronic equipment is poor installation. Therefore, always first check that:

- Installation and connection is made per instructions for instruments and transducers.
- Screw terminals are carefully tightened.
- No corrosion on any connection points.
- No loose ends in the wires, causing short cuts to adjacent wires.
- Cables for damage and that none are squeezed or worn.
- Battery voltage is sufficient, should be at least 11 V DC.
- The fuse is not blown and that the circuit-breaker has not opened.
- The fuse is of the right type.
- Two instruments do not have the same ID number.

7.2 Symptom - Cause - Action

In the table below, causes marked [*] are more likely to occur during installation or when rewiring has taken place.

Symptom	Cause	Action
Autopilot turns off	* Voltage below minimum.	Make sure 12/24 V is applied to battery terminals at Servo Unit.
Autopilot does not turn on	* Voltage not applied.	Make sure 12/24 V is applied to battery terminals at Servo Unit.
	* Voltage polarity is reversed.	Make sure + and - is applied to correct terminals
	* Boats safety switch is open.	Close the safety switch.
Autopilot turns on, but the pumpset does not run	* Fuse burned out.	Check and replace fuse as necessary, located in the Servo Unit.
	Slow blow (high current) fuse in Servo Unit is blown.	Replace fuse. If fuse regularly blows, check for excessive rudder load or mechanical defects in steering system
Pumpset motor turns but the rudder does not move	Pumpset drive section in Servo Unit may have failed to open.	Replace transistors, integrated circuits or entire circuit board.
	Broken or loose motor coupling.	Replace or tighten coupling as necessary.
	Pumpset contamination	Clean or replace pumpset

FAULT FINDING

Symptom	Cause	Action
Blinking [Low Bat] on bottom line of display	Low battery voltage. Automatic shut-off in case of voltage lower than 10.5 V (12 V battery) and 21.5 V (24 V battery).	Turn Autopilot off and charge batteries, or correct voltage loss. When proper voltage restores, restart Autopilot.
	Poor wiring connection.	Check for voltage drop and repair.
	Power wiring is undersized.	Replace wiring with correct diameter wire.
When Autopilot engaged, rudder goes hardcover.	APC routine not performed.	Perform APC routine.
	Power transistors in Servo Unit may be shorted.	Replace transistors or entire circuit board.
	Rudder transmitter linkage disconnected.	Re-connect and align as per installation instructions.
	Rudder transmitter wiring shorted or open circuit.	Check and repair wiring as necessary.
Autopilot wanders on some headings	Magnetic interference is present. The worst steering is usually on northerly headings in the northern hemisphere and southerly headings in the southern hemisphere.	Perform Auto-Deviation-Clear [CLR] and Auto-Deviation [DEV] again, or try another compass location. Investigate for magnetic disturbances around compass, e.g. masses of steel, motors, loudspeakers etc.
Autopilot wanders on all headings	Severe magnetic interference.	Choose another compass location.
	Air in hydraulics.	Fill and purge the steering system.
	Slack in the steering system.	Repair any loose or worn parts.
	Rudder transmitter potentiometer is "noisy" or intermittent.	Replace rudder potentiometer.
	Compass damaged; intermittent wiring connection	Repair any loose or worn parts; recheck and connect wiring.
	Slow wander means rudder control is set too low (understeering).	Increase Autopilot setting [P1] [RUD]
	Fast wander means rudder control is set too high (oversteering).	Decrease Autopilot setting [P1] [RUD]
Autopilot wanders on all headings.	Excess rudder load.	Reduce rudder friction, increase steering cylinder size, increase power of the pumpset.
Rudder movement is erratic	Air in system.	Check for leaks and bleed the system.
Rudder angle indicator is displaying erratic values.	Rudder transmitter is defective (noisy).	Replace rudder transmitter or potentiometer within.
	Check for loose or broken wires in terminal strips.	Reconnect tightly.
	Check for broken wires in cables.	If wiggling of cable where it flexes causes rudder activity, replace cable.
Boat overshoots on large course changes.	Rudder control set too high.	Decrease Autopilot setting [P1] [RUD]
	Counter rudder set too low.	Increase Autopilot setting [P3] [CRD]

	Cause	Action
--	-------	--------

FAULT FINDING

Course as set on Autopilot instrument is different from ship's steering compass.	If constant error, Autopilot compass is not aligned with for-aft line of boat.	Use Compass setting [C6] [ADJ] to adjust alignment of compass.
	Variable error in heading caused by magnetic interference.	Verify that the steering compass is accurately corrected and then correct the Autopilot compass as per installation instructions.
	Large errors not corrected by above remedies or lack of change in course set point with different headings indicate a defective compass.	<ol style="list-style-type: none"> 1. Run Auto-Deviation-Clear [C5] [CLR]. 2. Run Auto-Deviation [C3] [DEV] 3. Recheck compass again.
	Ships compass is not correct.	Compensate ships compass.
	Compass: no reading or wrong heading.	Check that the local magnetic variation [C2] [VAR] is set properly.
	Irregular values.	Check the Sea Damping [P2] [SEA].
NMEA does not engage, NAV arrow does not come on.	NMEA receiver not installed correctly.	Check receiver settings for proper output.
	No NMEA 0183 data received.	Check Nav cable for connection. to the correct port.
	Unreliable NMEA data detected upon engagement.	Check connections and setup in transmitting instrument
	No active waypoint.	Activate a waypoint.
After some use, NAV arrow does not come on.	Poor NMEA data detected. Last "good" NMEA heading is used until good data restored.	Check for poor navigator installation causing bad signal to noise ration. Check for erroneous data as detected by navigator. Revert to magnetic course only, if situation cannot be corrected.
Course under NAV steering is erratic.	May appear when close to waypoint due to GPS-S/A. error.	Accept situation or revert to compass course steering only.
	Compass heading information is not consistent with navigator.	Set heading in pilot i.e. true to true or magnetic to magnetic so course is consistent with navigator. Check NMEA wiring termination.

7.3 Nexus Network error messages with cause and remedy

If an error message [Err #] is displayed, an error has been detected by the Nexus Network. The message can assist you to diagnose the cause and remedy the error.

To escape from an error message, press any push-button. If not possible to escape, reset power (turn off and on again), then make the remedy if suggested below.

Note! For errors marked with [*], contact your national distributor to return the unit for rectification.

No.	Message and cause	Remedy	*
01	Activated watchdog timeout.	Reset power.	*
02	Nexus Network data frames are missing.	Check connections and setup.	
03	No data received within approx. 10 sec.	Check connections.	
04	EEPROM read.	Reset power.	*
05	EEPROM write.	Reset power.	*
06	RAM memory error.	Reset power.	*
07	Auto-log full, in GPS Compass.	Clear Auto-log memory.	
08	Break reset.	Reset power.	*
09	EEPROM auto initiation, or NMEA transmit fail. (Nexus Server only).	Reset power.	*
10	Range error, depending on wrong input e.g. 17° 70' = too many minutes.	Correct input format..	
11	Remote control setup error. Command can not be executed.	Check connections and settings.	
12	No response from navigator.	Check navigator connection and settings.	
13	Waypoint not defined.	Define a waypoint.	
14	Impossible command when used with an external NMEA navigator.	Use only possible command.	
15	Impossible command when in Autopilot mode.	Use only possible commands.	
16	Auto-deviation is not possible.	Check for extreme magnetic field, upside down mounting of transducer or wrong transducer type setting.	
17	Auto-deviation check failed.	1¼ turn not completed or extreme magnetic disturbance.	
18	Auto-deviation. Function denied.	Function denied since compass is busy with the auto-deviation routine.	
19	Auto-deviation failure.	Error larger than 1.5°. The boat probably hit a wave during the turn.	
20	GPS to CPU communication error.	Reset power.	*
21	GPS acquisition failure (time out).	Maximum allowed time for searching satellites. E.g. when try to navigate indoors. Check GPS antenna location.	
22	CPU to GPS communication error.	Reset power.	*
23	DGPS (RTCM) data ignored.	Change the DGPS (RTCM) setting.	
24	GPS bad fix, no fix position (time expired at one-fix).	Check GPS antenna location.	

FAULT FINDING

25	No Autopilot response. Object is not connected.	Check wiring connections and fuse.	
26	The unit is not allowed to power up because there is too high input voltage.	Check input voltage.	*
27	Extended object server busy or error.	Set one GPS Navigator instrument to master.	
28	Route command error. The waypoint bank memory is full.	Clear waypoint bank to make space.	
29	DGPS mode is interrupted.	Check the DGPS receiver.	
30-41	Reserved for Nexus Autopilot Servo Unit.	See Nexus Autopilot manual.	
42	Bad transducer input / bad measurement.	Reset power.	*
	Reserved for Nexus Autopilot Servo Unit.		
30	General Autopilot failure	Reset power.	*
31	Autopilot compass input failure in Autopilot standalone connection.	Check compass connection at Autopilot Servo Unit.	
32	Autopilot compass input failure in Autopilot Nexus Network connection.	Check compass connection at Nexus Server or at the Compass Data instrument	
33	Received wind data input failure.	Check wind wire connection.	
34	Autopilot calibration failure.	Check for air in the system and make APC routine again in calm water.	
35	Navigation data not available in Autopilot stand alone connection.	Check NMEA input connections and settings in the navigator.	
36	Navigation data not available in Autopilot Nexus Network connection.	Check connections and navigator settings.	
37	Autopilot Network re-initialisation.	Check connections and wire dimensions.	
41	Failure to initialise EEPROM.	Reset power.	*

8 Specifications

8.1 Technical Specifications

8.1.1 Autopilot instrument

Dimensions:	110 x 110 x 23 mm (4.3 x 4.3 x 0.9")
Weight:	260 g (9.17 oz)
Enclosure:	Water proof
Instrument cable:	0.4 m (16")
Power supply:	12 V DC (10-16 V). The instrument is polarity protected.
Power consumption:	0,08 W. At max lighting 0.8 W.
Current consumption:	7 mA (at 12V). At max lighting 70 mA (at 12V).

8.1.2 Servo Unit A-1500

Dimensions:	220 x 145 x 55 mm (8.7 x 5.7 x 2.2")
Weight:	800 g (28.2 oz)
Enclosure:	Splash proof
Cable:	8m (26ft) Nexus cable
Power supply:	12 or 24 V DC (10-40 V)
Power consumption:	4 W, plus drive unit demand
Current consumption:	0,3A (at 12V)
Max. motor output drive:	25 A
Output:	NMEA 0183 compass, RAI

8.1.3 Servo Unit A-1510

Dimensions:	160 x 110 x 38 mm (8.7 x 5.7 x 2.2")
Weight:	420 g (14.8 oz)
Enclosure:	Splash proof
Cable:	8m (26ft) Nexus cable
Power supply:	12 or 24 V DC (10-30 V)
Power consumption:	3 W, plus drive unit demand
Current consumption:	0,3A (at 12V)
Max. motor output drive:	15 A
Output:	NMEA 0183 compass, RAI

8.1.4 Rudder Angle Transmitter

Dimensions:	70 x 70 x 75 mm (2.7 x 2.7 x 3.0")
Transmitter arm:	120mm (4.7") long
Ball joint linkage arm:	2 arms, each 320mm (12,6") long
Weight:	170 g (6 oz) (without cable and linkage arm)
Enclosure:	Water proof
Cable:	15m (50ft), 3-lead.
Power supply:	From Servo Unit
Power consumption:	2,5mW
Current consumption:	0,5mA
Rudder angle:	± 55°
Resistance:	10kΩ
Life:	50 million cycles dither

Temperature range:

The above products have the same temperature range.

Storage: -30°C to +80°C. (-22°F to 176°F)

Operation: -10°C to +70°C. (14°F to 158°F)

Warranty period:

The above products have the same 2 year warranty period, see separate conditions.

CE approval:

The above products conforms to the EMC requirements for immunity and emission according to EN 5008-1 and EN 55022

8.2 Nexus Network specification

The Nexus Network is a high performance, non-collision multi-talker, multi-receiver data bus, specially designed for marine navigation applications. The most important features are the high update rate, fast response times, very low data latency (25ms) and very high data security even at long distances. Another important feature is that data transfer efficiency will not degrade even when used in large and complex systems. It utilises the RS485 standard with up to 32 senders and/or receivers to form a Local Area Network. Data is transmitted asynchronously with 1 start-bit, 8-data-bits, 1 parity-bit, two stop-bits in 9600 baud.

The link between Nexus Network and your PC-application is the PC interface FD (Full Duplex) / NMEA (Art. No. 21248-1). This is supplied with a 9-pole D-sub connector on a 1m (3.3 ft) cable for the RS232 PC port. The PC interface is a useful tool to monitor and log real time data, or when editing waypoints to/from PC-file or to/from Nexus Network. For users who writes there own software, please see our web-site where you find the Nexus application notes.

8.3 Accessories

8.3.1 Autopilot instrument

Additional Autopilot instruments (Art. No. 20445-5) may be added. They are connected in a "daisy chain" fashion from one to the other, matching colours on terminals. Control may be transferred from one instrument to another by simply pressing any pushbuttons (except the OFF push-button) on the instrument where active control is desired. All other inactive instruments will display the same information as the active instrument, however in the lower display the text "passive" will blink once every seven seconds.

8.3.2 Nexus Remote Control instrument

The Remote Control instrument (Art. No. 21210) is an instrument in itself that can be set in either Autopilot mode to be used as an Autopilot instrument, or Instrument mode displaying all information on the Nexus Network. Further it can be used as a remote control for all instruments connected to the Network. It is the ultimate Nexus instrument!

8.3.3 Nexus analog Rudder Angle instrument

The analog Rudder Angle instrument (Art. No. 20550-9) indicates the rudder angle (50° - 0 - 50°). This instrument is connected on the Nexus data bus cable as per colour codes.

8.3.4 Nexus Multi Control instrument with Server

The Nexus Server is the heart of the Nexus Network to which transducers for speed, depth, wind, compass and navigators are connected. The Multi Control is a Multi function instrument that displays a main and a sub-function, grouped into 4 pages for speed, depth

navigation and wind information. The Multi Control instrument and the Server are the building components of the Nexus Network.

8.3.5 External alarm buzzer

An external alarm buzzer (Art. No. 20081) can be connected to the Server only. The buzzer can be positioned where may be heard such as in the Captain's cabin, when any alarm is activated.

8.3.6 NFU jog lever

Non-follow up (NFU), jog or time dependent lever power steering, may be connected through the Autopilot Servo Unit to directly control the steering pumpset in any Autopilot function. This is useful for docking or remote manoeuvring such as required when picking up crab traps etc. In any Autopilot function, the jog steering can be used as a dodge function and when the jog lever is let go, the boat will revert to the previous course set by the Autopilot.

8.3.7 Other Nexus Accessories

Below is a selection of optional accessories that are available. Please contact your local Nexus dealer for more information.

Art. No. Nexus 'Completes'

20445-1	Speed Log complete with transducer
20445-2	Depth complete with transducer
21440	Wind Data complete with transducer
21732	Compass Data complete with 35° tilt transducer
21033-1	GPS Navigator complete with GPS Antenna
20445-3	Multi Control instrument complete with Server

Art. No. Nexus Transducers

20700	Log/Temp, 0 - 30 KTS, 8 m (26 ft) cable
20711-2	Depth, 0.8 - 150 m (2.6-490 ft), 3 + 8 m (10 + 26 ft) cable
20721	Wind transducer, 25 m (82 ft) cable
20860	Compass transducer 45° tilt, incl. 8 m (26 ft) cable
21000	GPS Antenna, Nexus/NMEA, 10 m (33 ft) cable
21731	Compass transducer 35° tilt, incl. 8 m (26 ft) cable
20721-1	Carbon-fibre wind transducer, (no mast cable incl.)
21721	MTC (Mast Twist Compensator) box incl. 8 m (26 ft) ca- ble

Art. No. Nexus Digital Instruments

20445-4.	Multi Control instrument
21434-1	Wind Data instrument
21487	Compass Data instrument
21032	GPS Navigator instrument
20445-5	Autopilot instrument
21210	Remote Control instrument
21680-1	Multi XL instrument
21684-2	Multi XL Set, incl. Remote Control instrument
21621	Multi Center

Art. No.	Nexus Analog Instruments
20550-2	Steer Pilot analog
20550-1	Wind Angle analog
20550-6	Compass analog
20550-3	Speed analog, 0-16 KTS
20550-4	Speed analog, 0-50 KTS
20550-5	Depth analog, 0-200 m
20550-7	Depth analog, 0-600 FT
20550-8	Speed Trim analog, 20% - 0 - 20%
20550-9	Rudder Angle analog, 50 - 0 - 50
Art. No.	Nexus Autopilot
21035	Servo Unit A-1500
21035-2	Servo Unit A-1510
21036	Rudder angle transmitter
21134	Pumpset 12V PF-0,3, for hydraulic steering
21341	Pumpset 12V PF-0,3 with solenoid, for mechanical steering
21136-2	Cylinder SP-20, stroke 200 mm
Art. No.	Other Nexus Accessories
19841	Maxi Repeater yellow digits, NMEA repeater
19941	Maxi Repeater red digits, NMEA repeater
69999	Mast bracket Maxi, for two Maxi repeaters
69995	Mast bracket XL, for Multi XL and standard Nexus
110x110	
21556	Connection box Nexus Network
21453	Connection box Wind Data and Compass incl. 6 m (19 ft) cable
21248-1	PC Interface FD (Full Duplex) / NMEA with 1 m (3.3 ft) cable and a 3½"disc.
20438	Instrument cover Nexus instruments 110 x 110 mm
20443	Nexus extension cable, per meter
21266-8	Nexus cable 8 m (26 ft) with wire protectors at each end
20594	Nexus mast cable 25 m (82 ft)
18129	Instrument panel for up to 6 Nexus 110x110 mm instruments
19763	Remote push button for extern MOB or Trim function
20081	External alarm buzzer, for Nexus Server
19038	Internal mounting kit for depth transducer
19216	Through hull fitting - bronze
21154	Paddlewheel blue with axle, high speed 0-50 kts
67400-15	Mast top adapter 15° aluminium
18500	Through deck connector 7-pole
18501	Through deck connector 4-pole
20966	Connector 4-pole

8.4 Abbreviations

Abbr.	Description
ADJ	ADJ ust
ALM	AL ar M
APC	A utomatic P ilot C alibration
ATC	A utomatic T rim C ontrol
AWA	A pparent W ind A ngle
BAT	BAT tery
BOD	B earing O riginal D estination
BRG	BeaR in G
BSP	B oat SP eed
BTW	B earing T o W aypoint
C10	C alibrate 10
CAL	CAL ibrate
CDI	C ourse D eviation I ndicator
CE	C ommunaute E uropéenne
CHK	CH eck
CLR	CL ea R
COG	C ourse O ver G round
CTS	C ourse T o S teer
d	d ifferential
DEV	DE viation
DGPS	D ifferential GPS
dGPS	d ifferential GPS
DTW	D istance T o W aypoint
E	E ast
Edit	E dit
EEPROM	E lectronically E rasable P rogrammable R ead O nly M emory
EMC	E lectro M agnetic C ompatibility
EN	E uropean N orm
GPS	G lobal P ositioning N etwork
HDC	H ea D ing C ompass
HDM	H ea D ing M agnetic
HDT	H ea D ing T rue
HM	H ea D ing M agnetic
HT	H ea D ing T rue
id	i dentity
INI	I N I tiation
Init	I n i tiation
KT	K no T s
KTS	K no T S

LCD	Liquid Crystal Display
LOW	LOW
m	metre
m/s	metres per second
MAG	M agnetic North
MAX	MAX
MEM	MEM ory
MID	MID
MIN	MIN imum
MN	M agnetic North
MOB	Man Over Board
N	N orth
NAV	NAV igate
NM	N autical Mile
NMEA	N ational M arine E lectronic A ssociation
OCA	Off Course Alarm
PCA	Pilot Course Alarm
PWR	PoWeR
RAM	R andom A ccess M emory
RET	RET urn
RRS	R udde R Speed
RUD	RUD der
S	S outh
S/A	S elective A vailability
SAT	SAT ellite
SEA	SEA
SEC	SEC onds
SOG	S peed O ver G round
STR	ST ee R
tru	tru e
USR	US e R
VAR	V ARiation
VER	VER sion
W	W est
WP	W ay P oint
XTE	Cross Track error

The boat is left of the desired track

 The boat is right of the desired track

 Apparent wind angle from port

 Apparent wind angle from starboard

 Rudder angle port

 Rudder angle starboard

 Minus

 Plus

8.5 Warranty

WARRANTY

GENERAL

All our products are designed and built to comply with the highest class industry standards. If the products are correctly installed, maintained and operated, as described in the installation and operation manual, they will provide long and reliable service. Our international Network of distributors can provide you with the information and assistance you may require virtually anywhere in the world.

Please read through and fill in this warranty card and send it to your national distributor for product registration.

LIMITED WARRANTY

The warranty covers repair of defective parts due to faulty Manufacturing and includes labour when repaired in the country of purchase. The warranty period is stated in the product manual, and commences from the date of purchase. The above warranty is the Manufacturer's only warranty and no other terms, expressed or implied, will apply. The Manufacturer specifically excludes the implied warranty of merchantability and fitness for a particular purpose.

CONDITIONS

- The supplied warranty card and receipt with proof of purchase date, must be shown to validate any warranty claim. Claims are to be made in accordance with the claims procedure outlined below.
- The warranty is non-transferrable and extends only to the original purchaser.
- The warranty does not apply to Products from which serial numbers have been removed, faulty installation or incorrect fusing, to conditions resulting from improper use, external causes, including service or modifications not performed by the Manufacturer or by its national distributors, or operation outside the environmental parameters specified for the Product.
- The Manufacturer will not compensate for consequential damage caused directly or indirectly by the malfunction of its equipment. The Manufacturer is not liable for any personal damage caused as a consequence of using its equipment.
- The Manufacturer, its national distributors or dealers are not liable for charges arising from sea trials, installation surveys or visits to the boat to attend to the equipment, whether under warranty or not. The right is reserved to charge for such services at an appropriate rate.
- The Manufacturer reserves the right to replace any products returned for repair, within the warranty period, with the nearest equivalent, if repair within a reasonable time period should not be possible.
- The terms and conditions of the warranty as described do not affect your statutory rights.

CLAIMS PROCEDURE

Equipment should be returned to the national distributor, or one of its appointed dealers, in the country where it was originally purchased. Valid claims will then be serviced and returned to the sender free of charge.

Alternatively, if the equipment is being used away from the country of purchase, it may be returned to the national distributor, or one of its appointed dealers, in the country where it is being used. In this case valid claims will cover parts only. Labour and return postage will be invoiced to the sender at an appropriate rate.

DISCLAIMER

Common sense must be used at all times when navigating and the Manufacturer's navigation equipment should only be considered as aids to navigation.

The Manufacturers policy of continuous improvement may result in changes to product specification without prior notice.

File id:

WARRANTY CARD

TO BE RETURNED TO YOUR NATIONAL DISTRIBUTOR

OWNER:

Name: _____

Street : _____

City/Zip Code : _____

Country: _____

Product name:

Serial number:

	A	B	C	1	2	3	4	5	6	7
_____	<input type="checkbox"/>	<input type="checkbox"/>	<input type="checkbox"/>	<input type="checkbox"/>	<input type="checkbox"/>	<input type="checkbox"/>	<input type="checkbox"/>	<input type="checkbox"/>	<input type="checkbox"/>	<input type="checkbox"/>
_____	<input type="checkbox"/>	<input type="checkbox"/>	<input type="checkbox"/>	<input type="checkbox"/>	<input type="checkbox"/>	<input type="checkbox"/>	<input type="checkbox"/>	<input type="checkbox"/>	<input type="checkbox"/>	<input type="checkbox"/>
_____	<input type="checkbox"/>	<input type="checkbox"/>	<input type="checkbox"/>	<input type="checkbox"/>	<input type="checkbox"/>	<input type="checkbox"/>	<input type="checkbox"/>	<input type="checkbox"/>	<input type="checkbox"/>	<input type="checkbox"/>
_____	<input type="checkbox"/>	<input type="checkbox"/>	<input type="checkbox"/>	<input type="checkbox"/>	<input type="checkbox"/>	<input type="checkbox"/>	<input type="checkbox"/>	<input type="checkbox"/>	<input type="checkbox"/>	<input type="checkbox"/>
_____	<input type="checkbox"/>	<input type="checkbox"/>	<input type="checkbox"/>	<input type="checkbox"/>	<input type="checkbox"/>	<input type="checkbox"/>	<input type="checkbox"/>	<input type="checkbox"/>	<input type="checkbox"/>	<input type="checkbox"/>
_____	<input type="checkbox"/>	<input type="checkbox"/>	<input type="checkbox"/>	<input type="checkbox"/>	<input type="checkbox"/>	<input type="checkbox"/>	<input type="checkbox"/>	<input type="checkbox"/>	<input type="checkbox"/>	<input type="checkbox"/>

Date of purchase: _____ Date installed _____

Dealers stamp:

Tick here if you do not wish to receive news about future products

9 Installation

9.1 Installation general

Reliable and accurate operation of an Autopilot depends more on correct installation than any other piece of marine electronics. Please read and fully understand the installation requirements before attempting installation.

Note! If in doubt, obtain the services of an experienced Autopilot installation technician.

- **The installation includes 8 major steps:**
 1. Read the installation and operation manual.
 2. Plan where to install the different parts.
 3. Make the attachments needed for Pumpset and Cylinder and install them.
 4. Run the cables.
 5. Install the transducers and instruments.
 6. Take a break and admire your installation.
 7. Learn the functions and calibrate your systems.
 8. Make the Dockside Testing before the Sea Trials.

Before you begin drilling ... think about how you can make the installation as neat and simple as your boat will allow. Plan where to position the transducer and the instrument. Think about leaving space for additional instruments to be fitted in the future.

A few "do nots" you should consider:

- Do not cut the cables too short. Allow extra cable length at the instrument so it can be disconnected for inspection without having to disconnect all attached cables.
- Do not place sealant behind the instrument. The gasket eliminates the need for sealant.
- Do not run cables in the bilge, where water may accumulate.
- Do not run cables close to fluorescent light sources, engine or radio transmitting equipment, in order to avoid possible electrical disturbances.
- Do not rush, take your time. A neat installation is easy to do.

The following material is needed:

- Wire cutters and strippers
- A pair of flat pliers
- Small and large Philips and flat head screw driver
- Hole saw for the instrument clearance hole 50 mm (2")
- Drill for the mounting holes (2,8 mm 0,11" for the instrument)
- Cable ties

Additional parts for installation: All parts needed for installation are included, for the Autopilot instrument and compass. For the Servo Unit, Rudder Angle Transmitter, Pumpset and Linear Drive, the following material is not supplied and need to be sourced or made locally: safety switch, power cables, screws / bolts / nuts and support bracket for mounting, hydraulic fittings, piping and oil. This is because most installations differ.

9.2 Installation alternatives

This section covers installation of Autopilot instrument, Servo Unit and Rudder Angle Transmitter. For the installation of compass transducer, pumpset, linear drive, see separate instructions supplied with each product.

You can install the Nexus Autopilot for two different applications:

- Stand alone Autopilot application.
- Nexus Network application, by connecting it to the Nexus Network.

9.3 Autopilot instrument

9.3.1 Location of instrument

The instrument is designed to be front mounted above or below deck. It should be mounted on a flat and smooth surface. This condition must be followed to ensure the gasket seals correctly against the mounting surface. Mount the instrument so that it:

- can be reached by the helmsman to transfer from manual to automatic steering,
- is satisfactory protected from outer damage,
- is at least 500 mm away from radio receiving equipment,
- has sufficient clearance from behind, for the instrument housing and cables.

Note! The instrument can be mounted right next to a magnetic compass.

9.3.2 Installing instrument

- Place the adhesive drill template on the desired location for the instrument.
- Drill the holes for the mounting screws, using a 2,8 mm (0,11") drill. Use a 50 mm (2") hole saw, to machine the clearance hole for the instrument connection socket. Remove the template.

Warning! Do not drill through the instrument mounting holes as the gaskets may be damaged and thus cause leakage. The warranty is not valid for damage caused by drilling through the mounting holes.

- Run the Nexus Network cable from the Autopilot Servo Unit to the instrument.
- Cut the Nexus Network cable to length. Peel off about 35 mm (1 1/4") of the cable insulation. Remove about 6 mm (1/4") from the 3 isolated wires (the 4th wire is an earth/screen). Attach the 4 cable protectors to the wires using a pair of flat pliers.
- Connect the 4 cable protectors to the 4-pole jack plug as shown.
- **Important!** Apply silicon paste to all areas as shown to avoid corrosion.

INSTALLATION

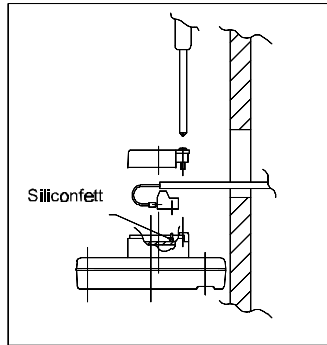
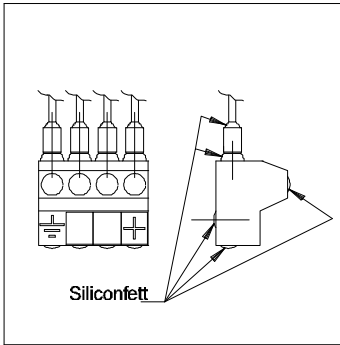

- Apply silicon paste to the instrument connection pins at the back of the instrument. Press the jack plug into the instrument pins. Press down the cable in the cable leads. Mount the connection back cover with the screw.
- Mount the instrument in the pre-drilled position.

Important! Use all 4 screws and tighten the screws (in cross pattern) so the gasket will be evenly compressed to 1/3 of its original thickness. Very important for a correct sealing to avoid leakage!

- Press on the 4 rubber caps to seal and hide the mounting screws.

Additional instruments can be connected either in a "daisy chain" configuration from one to the other, or in a "star" configuration, matching colours as above.

The instrument cable should be connected to the Servo Unit terminals marked "Bus/Control head(s)" matching the colours as indicated, see drawing in connection Servo Unit below.

9.4 Wire thickness

Important! Use the following table to determine wire thickness. Total distance from battery to Servo Unit and distance from Servo Unit to pumpset must be used to determine the wire thickness from the table.

Cable Length Max m (ft)	Wire Size (mm ²)	Wire Size (AWG)
3 (10)	2.5	14
5 (16)	4	12
7.5 (25)	6	10
12 (40)	8	8

Make sure, that the wire size between the battery and the point where you will connect the wire to the Servo Unit is big enough to secure power supply to all other connected electrical units on board. If you are in doubt, ask your local electrician.

9.5 Servo Unit

9.5.1 Location of Servo Unit

The Servo Unit must be mounted on a dry, flat and vertical surface below deck, at least 500 mm (20") from radio receiving equipment. Since all wiring originates at the Servo Unit, it should be centrally located to minimise lengths of wiring. It is most important to minimise the runs of power and motor leads since voltage drop in these cables will reduce steering capacity.

9.5.2 Installing Servo Unit

To mount the Servo Unit, remove its cover screws. The 4 inner mounting holes are now exposed. Mount the Servo Unit with 4 screws (not supplied).

9.5.3 Connecting Servo Unit

Servo Unit connections should be according to below drawing.

Note! If any waterproof cable glands do not have cables inserted, install the short rubber plug provided in order to maintain water tightness. If many options are connected and not enough glands are available, use a separate junction box and route the excess wires through one large cable in one of the large glands.

Note! Autopilot instrument / Nexus Network connection. If you want to run the Nexus Network instruments separate from the Autopilot, do not connect green wire to (pin 1) to the left in Servo Unit. Instead insulate the green wire.

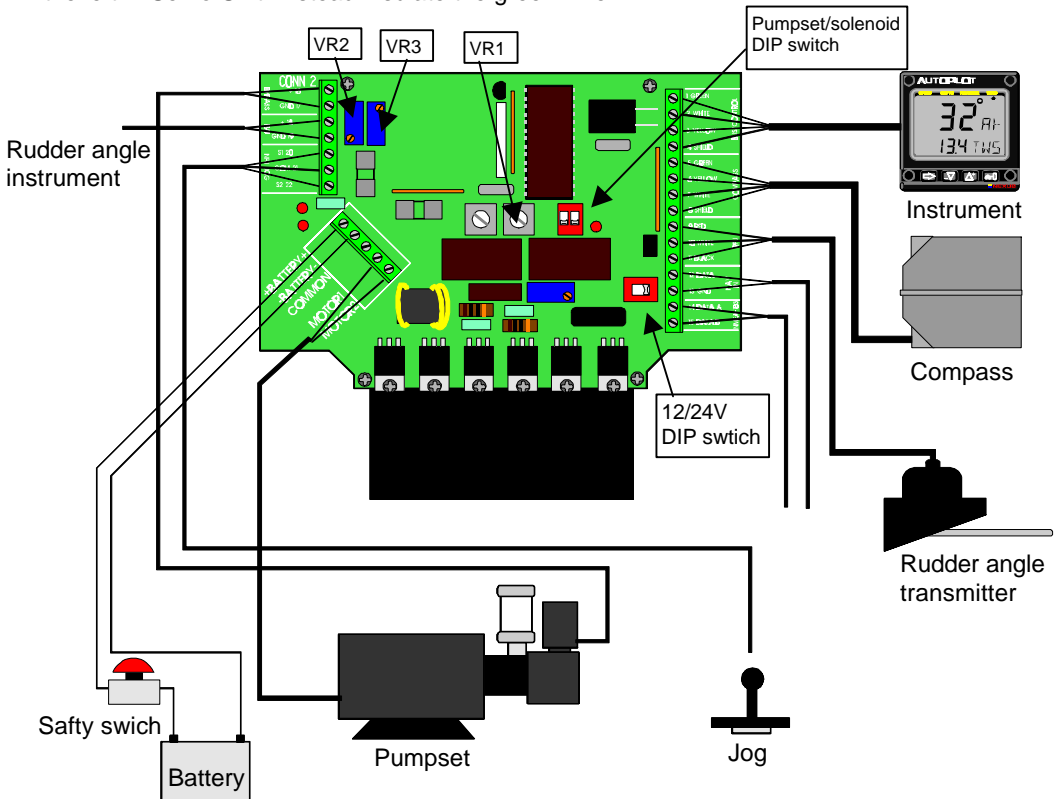

INSTALLATION

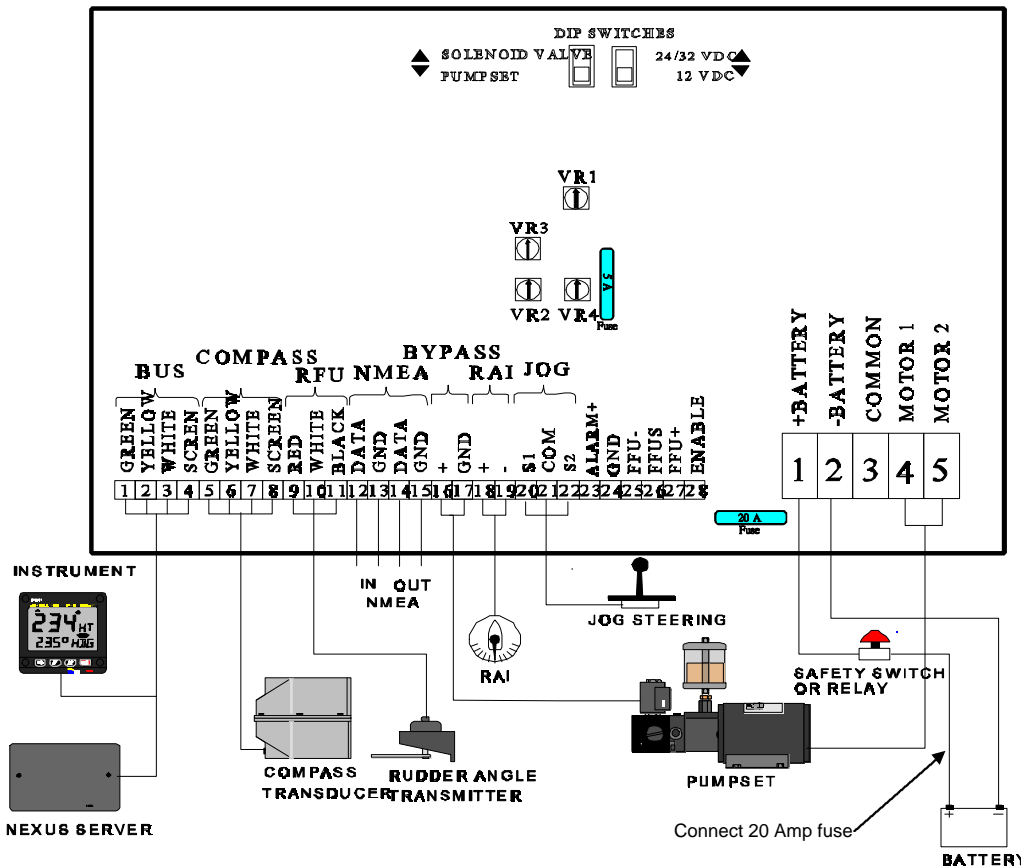

9.5.4 Safety switch

Important! An external safety switch or circuit breaker (relay) (not supplied) should be installed in line with power input. Make sure it is rated greater than or equal to 25 Amps. **This switch will serve as your Autopilot ultimate safety OFF switch.**

9.5.5 Dip switches

The main circuit board has 2 dip switches which must be pre-set during installation to suit the installed configuration.

Important! With power turned off to the system, do the following:

- Locate dip switch for 12 or 24/32 VDC voltage and make sure it is set to the voltage supply connected.
- Locate dip switch for "solenoid valve" or "pumpset" and make sure it is set to the type of drive you have installed.

9.5.6 Trim potentiometers

If a non-Nexus brand rudder angle indicator is fitted, it can be calibrated with the 2 trim potentiometers as indicated on drawing. Adjust VR3 labelled offset, for rudder centre and VR2 labelled gain, for maximum deflection.

Note! This is just to calibrate any non-Nexus rudder angle instrument. The Nexus instruments must be calibrated by changing the rudder angle transmitter arm length.

9.5.7 NMEA connections

NMEA input from GPS Navigators etc. can be connected to Servo Unit terminals 12 (data) and 13 (ground). For NMEA input, the overall shield should be terminated at the external unit, and not at the Servo Unit.

NMEA output from Compass transducer can be taken from Servo Unit terminals 14 (data) and 15 (ground). For NMEA output, the overall shield should be terminated at the Servo Unit, and not at the external unit.

9.6 Rudder angle transmitter

The rudder angle transmitter should be mounted close to the rudder stock and driven by its ball joint linkage according to the drawing shown below. The linkage should be linear, such that 35° of rudder movement drives the arm 35°.

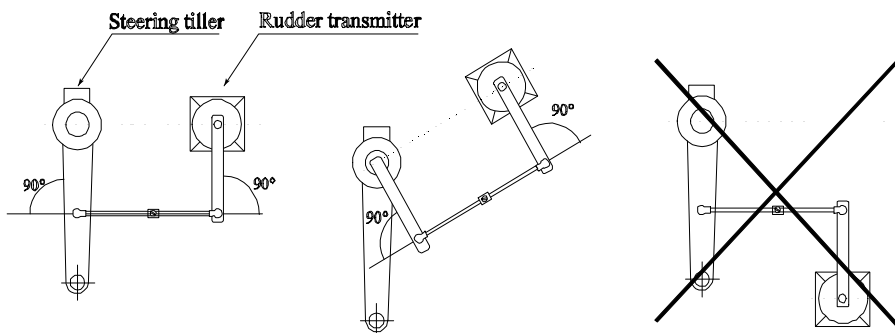

Small errors will not affect Autopilot operation but will cause inaccurate indication on the rudder angle indicator. If possible, the linkage on the rudder transmitter should be adjusted so that the digital rudder angle indicator on the Instrument display is consistent with the rudder angle. The cable should be connected to Servo Unit terminals marked "RFU" according to colours indicated.

The rudder transmitter unit must be securely mounted to a vertical surface and connected by the adjusting tie rod linkage to the tiller, maintaining the geometry as detailed in the diagram shown. The rudder transmitter arm must always swing in the same plane as the tiller. Make sure all fasteners are well tightened and locked. For maximum watertight integrity it is recommended that the unit is mounted with its rotary shaft facing downward.

9.7 Pumpset

For installation and specification, see separate manual.

9.8 Linear drive

For installation and specification, see separate manual.

Figure 1: Typical installation on a boat with mechanical steering, including Pumpset PF-0,3S with solenoid.

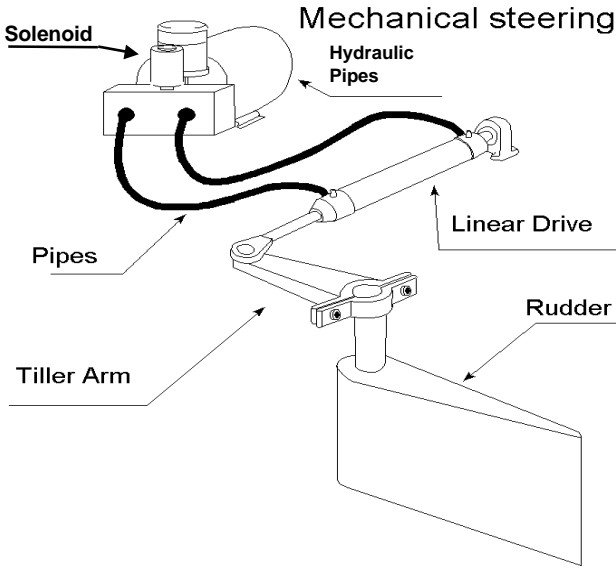
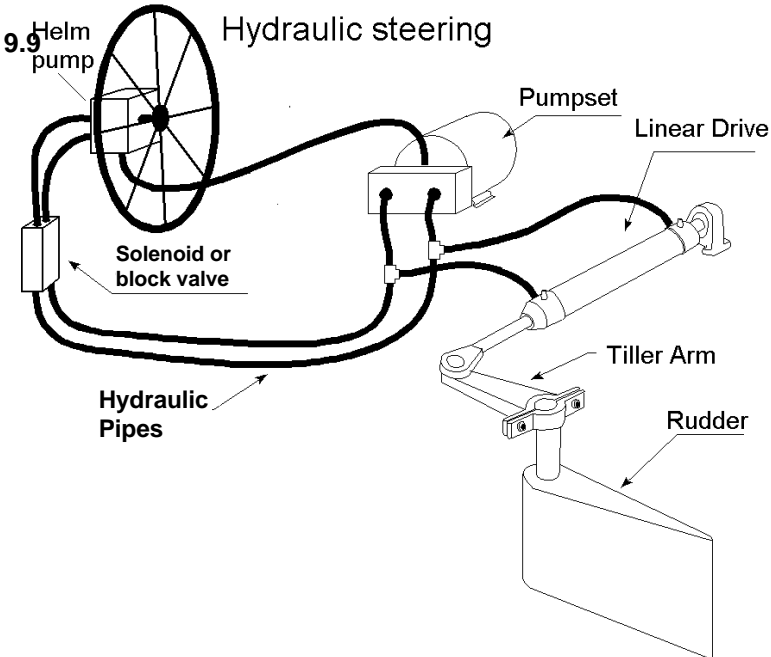

Figure 2: Typical installation on a boat with hydraulic steering, including Pumpset PF-0,3.



Solenoid valve controlled pumpset

If the boat is already fitted with a hydraulic steering with a solenoid valve controlled pumpset for 12 or 24 VDC, connect one solenoid coil to Servo Unit terminal "Common" (-) and terminal "Motor 1" (+) and the other to terminal "Common" (-) and terminal "Motor 2" (+).

Make sure that the Servo Unit dip switch "solenoid valve" (change all switches on the DIP) has been selected.

Solenoid valve controlled pumpset should be adjusted to speeds of 14 seconds hard over to hard over or slower for maximum accuracy. Higher rudder speeds will require increased anti-hunt settings to prevent hunting (overshoot of the rudder).

To adjust anti-hunt setting, first complete procedures in described in sections Setup, Dockside Testing and Sea Trials. Activate the Autopilot and with the pumpset running, make 10° course changes to port and starboard.

If the rudder hunts (i.e. oscillates rapidly back and forth during these course changes, gradually increase the anti-hunt control (i.e. adjust VR1 trim potentiometer) until the rudder remains stable. Do not increase the anti-hunt control any more than necessary, as this can begin to degrade course accuracy.

9.10 Other Accessories

Install any accessories as per their instructions and connect them according to wiring as shown in Servo Unit wiring drawing.

When you finished the installation, perform the Dockside Testing routine.

10 Dockside Testing

10.1 Preparations

Start checking the following:

- Familiarise yourself with the operating procedures by reading sections Operation, Function and Setup.
- Double check all wiring connections and dip switch settings prior to connecting power to the system.
- Make sure rudder angle limit [LIM] is set to 99° (OFF).
- Ensure that the oil reservoir is 3/4 full and maintain that level throughout the test procedure.

Warning! Do not activate any of the 3 Autopilot functions Compass, Nav or Wind at dock as the rudder may go hard over, since the APC routine has not been carried out yet. It will be done as explained in Sea Trials.

10.2 Dockside First Start

Run the procedure as described in First Start.

10.3 How to remove air from system

Select PWR ST function by pressing **MODE** until the page-arrow appears under PWR ST. To activate the Autopilot, press **KEY**.

Press and hold **LEFT** or **RIGHT** until the pumpset begin to run and the rudder moves.

If port rudder is given when you press starboard (**RIGHT**) push-button, and vice versa, ignore the reversal. It will be corrected automatically when doing the APC routine at Sea Trials.

It may take time before the steering begins to move due to air in the system. Continue to press and hold the push-button until the steering reaches its stops. Then reverse direction with the opposite push-button. Repeat this procedure 10 times or more until the system appears to move smoothly.

After 5 or 10 minutes of this purging, let the system rest so that entrained air can settle out of the oil. After 5 minutes of rest, repeat the above procedure.

Air in the system may cause noisy pumpset operation. When the pumpset becomes quieter and the steering moves smoothly and the linear drive responds instantly in both directions, it may be assumed that most air is out of the system.

To check that all air is removed, select power steer function and try to turn the steering wheel. In this function the steering wheel should be stiff. If you can turn the wheel a certain amount with a increasing pressure as a result, there is still air in the system. Continue to ventilate the system until the steering wheel is stiff before you proceed with the sea trials.

Do not attempt to activate the Autopilot in other functions than power steer, until all air is out of the system, as sloppy course holding will result. The very last air removal will be done as the boat is tested underway.

When you finished the Dockside Testing, perform the Sea Trials routine.

11 Sea Trials

11.1 Preparations

Take your boat out in half speed to calm sea and away from other boats or obstructions to run the sea trials. Then proceed as per below order.

Warning! Do not activate any of the 3 Autopilot functions Compass, Nav or Wind at dock as the rudder may go hard over, since the APC routine has not been carried out yet.

11.2 Compass calibration

Enter the compass calibration.

Note! If you are using an existing Nexus Compass transducer that already has been compensated, it is not necessary to run the auto-deviation [Auto DEV] procedure again.

Local Magnetic Variation:

Run the calibration routine local variation [VAR].

Automatic Compass Compensation:

Run the calibration procedure auto-deviation [Auto DEV].

Automatic Compass Check

Run the calibration procedure auto-deviation-check [Auto CHK].

Misalignment correction

Run the calibration procedure compass alignment [ADJ].

11.3 Automatic Pilot Calibration [APC]

The Autopilot will not function unless the boat pass the APC routine. The APC will automatically determine and correct how wires and pipes are connected. It will also learn how the boat reacts on different rudder commands and automatically calibrate itself.

The APC routine automatically sets: [RUD], [SEA], [CRD], [ATC] and [RRS].

Select P7 [APC]. To unlock, press **KEY**. To change to [On], press **LEFT** or **RIGHT**. To activate the APC, press **KEY**.

All 4 page arrows at top of display will now be lit to confirm the APC procedure is in action. The boat should automatically turn slightly to port and starboard and return to original course.

If the APC fails: Error message 34 (calibration failure) is displayed. This is most likely caused by too much air still in the system. To escape the error message, press any push-button. Revert to 10.3. "How to remove air from the system". **Note!** You can "help" the APC process by manually pulling the steering wheel or tiller in same direction as APC turns the boat to pass the APC.

If the APC is successful: All 4 page-arrows disappear, the instrument leaves the setup mode and returns to standby mode automatically.

Note! You may interrupt the APC routine at any time by a press on **KEY**.

Congratulations, your Autopilot calibration is done. Now go ahead and activate the Autopilot and enjoy the Nexus performance.

12 Fine tuning

The factory default settings and the APC routine will provide acceptable performance for most boats, but each boat has different steering characteristics and some fine tuning may be necessary for optimum performance.

For individual settings referred to below, see the setup section.

The tests should be performed under fairly calm sea conditions with minimal wind or tide. If wind or tide are unavoidable, set a course for minimum effects from these causes. It is recommended that these sea trials should not be done in restricted or busy waters.

Step by step instructions how to fine tune the Autopilot:

1. Check that Dockside Testing, Sea Trials including the APC routine has been done. If not, go back and make sure they are done.
2. Activate the Autopilot on a course and ensure that it holds without excessive understeering or oversteering.
3. With the boat travelling in a straight line at its normal cruising speed in calm water, activate the Autopilot compass function. Make a 40° course change using the **LEFT** or **RIGHT** and the boat should not overshoot by more than 3° to 4°. Continue making 40° course changes while adjusting the Rudder [RUD] setting until the boat overshoots the correct course a few times prior to setting on the course. This is the optimal [RUD] setting that can be used on the boat at the current cruising speed and load, in calm waters.
4. Continue making 40° course changes while slowly increasing the Counter Rudder [CRD] setting, until the boat settles onto course with only one overshoot of 2° to 3° or less. On some boats, the [RUD] setting may have to be decreased by one position to get the boat to control properly. The [RUD] and [CRD] settings are set to the maximum combined settings that should be used on the boat at that speed and under the existing sea conditions.

The [RUD] and [CRD] settings may need to be increased in rough weather. The higher the [CRD] setting relative to the [RUD] setting for calm weather, the less it will need to be increased in rough weather. As the boat's speed decreases, the rudder becomes less effective.

The [RUD] and [CRD] settings may need to be increased as the speed decreases. The higher the [CRD] setting relative to the [RUD] setting, the less it will need to be increased at lower speeds.

To find the optimal [RUD] and [CRD] settings at different boat speeds, or when the boat is towing, follow the procedures outlined in #3 and #4 above. Make a record of the different settings needed to control the boat at all typical speeds, loads and weather conditions normally experienced. Due to the wide dynamic control range and self tuning features of the microprocessor control, settings determined for cruising speed in calm seas may be found acceptable without further change at slower speeds and in heavier seas.

5. The compass damping [SEA] setting is a combination of yaw dead-band (compass sensitivity) and compass damping. The minimum setting may only be used under calm sea conditions to avoid unnecessary rudder correction due to compass acceleration errors.

Smaller boats and high speed boats which are subject to more acceleration in lighter seas will have to use higher settings.

Larger and more stable boats can use lower settings since there is less compass disturbance. Factory default setting should work on most boats in light to moderate sea conditions.

Following seas, no matter how rough, may require lower settings to catch course error trends quickly in order to minimise excessive yaw and steering activity.

6. Automatic Trim Calibration [ATC] adjustment is not critical. It constantly compares the course set against the course steered. The automatic trim slowly applies more rudder as necessary to reduce any persistent errors to zero. Such errors may exist due to wind, waves or other unbalanced forces such as single screw operation of a twin screw boat, an off centre tow or weather helm on a sailing boat. If the trim time is set too high, it will take a long time to eliminate the course error. If it is set too low it can start to degrade course stability.

In general, longer trim times (higher settings) should be set for large boats and sailing boats and shorter trim times (lower settings) for small boats and high speed planning boats. The factory default setting should be acceptable for all but extreme applications. If after fine tuning all routines and auto-deviation routine has been done and poor steering is noted only on some but not all headings, magnetic interference is present which must either be compensated for by a compass adjuster and/or another compass location must be found.